

C.I.P.**30-30 Win.**

TAB. II

Date 84-06-14

Revision 02-05-15

Country of Origin: US

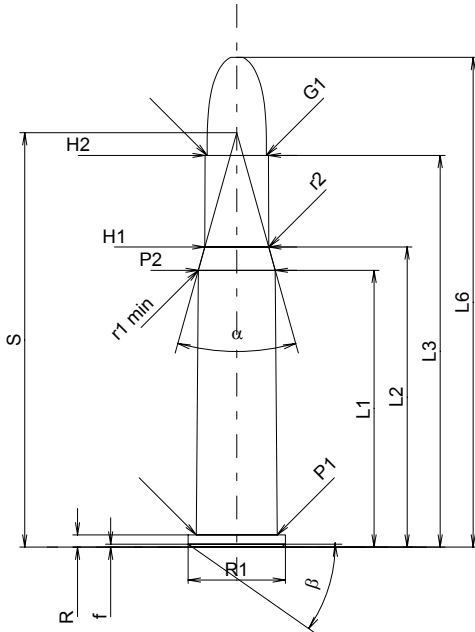
**CARTRIDGE MAXI****Lengths**

L1	=	36.60
L2	=	39.69
L3 ¹⁾	=	51.80
L4	=	
L5	=	
L6	=	64.77

Case Head

R ¹⁾	=	1.60	-0.25
R1	=	12.85	
R3	=		
E	=		
E1	=		
e min	=		
delta	=		
f	=	0.38	
beta	=	35°	

Powder Chamber

P1	=	10.71
P2*	=	10.19

Junction Cone

alpha*	=	31°18'
S*	=	54.79
r1 min	=	4.57
r2	=	11.68

Collar

H1*	=	8.46
H2 ¹⁾	=	8.38

Projectile

G1 ¹⁾	=	7.85
G2	=	
F	=	
L3+G ¹⁾	=	53.25

Pressures (Energies)**Method Transducer**

Pmax	=	3200 bar
PK	=	3680 bar
PE	=	4000 bar
M	=	25.00
EE	=	2445 Joule

Miscellaneous Dimensions

Fe ¹⁾	=	0.15
delta L	=	

CHAMBER MINI**Lengths**

L1	=	36.95
L2	=	40.10
L3 ¹⁾	=	52.91

Breech

R ¹⁾	=	1.60
R1	=	13.11
R2	=	
R3	=	
r	=	

Powder Chamber

E	=	
P1 ¹⁾	=	10.75
P2*	=	10.24

Junction Cone

alpha*	=	31°18'
S*	=	55.23
r1 max	=	4.57
r2	=	11.68

Collar

H1*	=	8.48
H2 ¹⁾	=	8.40

Commencement of Rifling

G1 ¹⁾ *	=	8.40
G ¹⁾	=	1.45
alpha1*	=	30°
h	=	
s	=	
i ¹⁾ *	=	15°
w	=	

Barrel

F ¹⁾ *	=	7.62
Z ¹⁾	=	7.82

Grooves

b	=	2.39
N	=	6
u	=	305.00
Q	=	47.06 mm ²

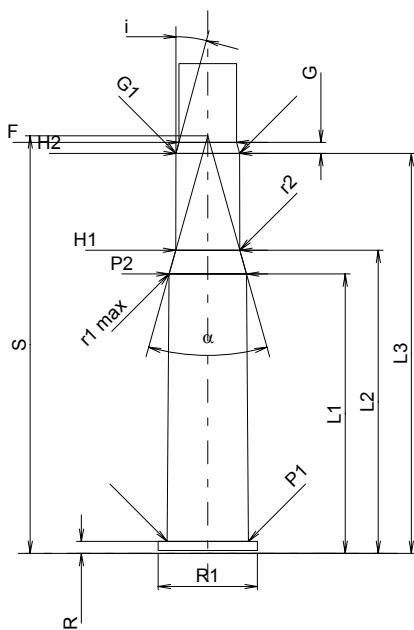

Scale 1:1

Dimensions in << mm >>
Dimensions and Tolerances for Proof Barrels
see Appendix CR 1.

Notes: 1) Check for safety reasons
* Basic dimensions